



Air-Powered Gearmotors

16AM Series, 20:1 reduction, 775 – 5200 lbs. in. (90 – 580 Nm) torque at 15 rpm (minimum speed reduction)



MODEL

16AM-13-HB20

(6 Vanes, Reversible)

Net wt. for standard configuration
163 lbs. (73,4 kg)

FEATURES

- 20:1 gear reducer
- Base mounting
- Optional mountings and shaft locations available

RECOMMENDED

- Filter AH109F
- Regulator AH110R
- Gauge AA806
- Lubricator AH111L
- Muffler AG601
- Oil AD220 – 1 quart (.94 litres)
- Repair kit K213 (Air motor only)

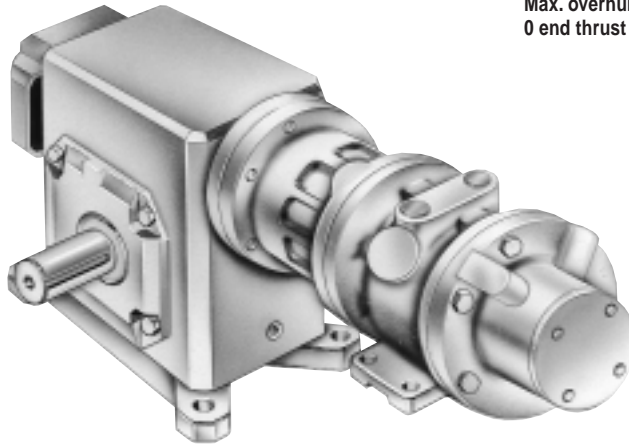

Max. allowable end thrust with 0 overhung load is 3552 lbs. (1598,4 kg) at 30 rpm to 2154 lbs. (969,3 kg) at 100 rpm. Max. overhung load on output shaft with 0 end thrust 2857 lbs. (1285,7 kg).

“B” Mounting (photo)

16AM-13-HB20 / *16AM-13-HF20
(standard shaft) / (opposite shaft)

inches / mm

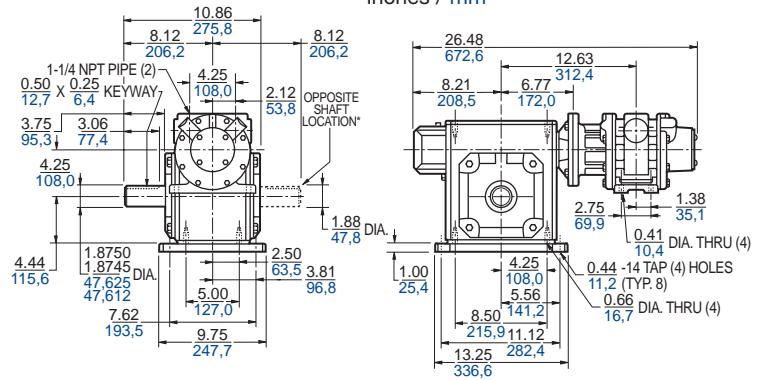

Output Power vs. Speed

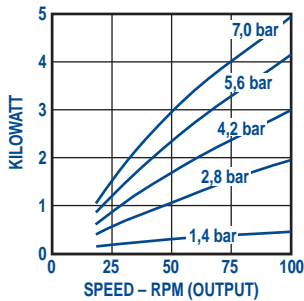
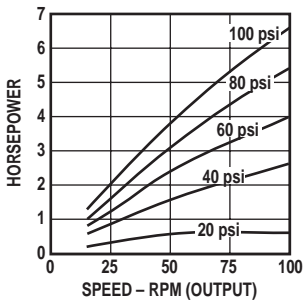

Torque vs. Speed

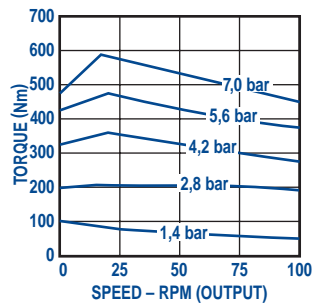
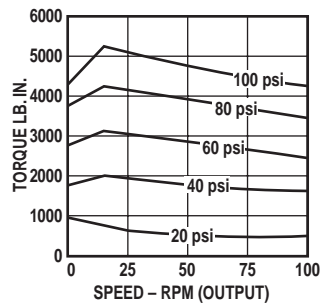

“C” Mounting

16AM-13-HC20 / *16AM-13-HG20
(standard shaft) / (opposite shaft)

inches / mm

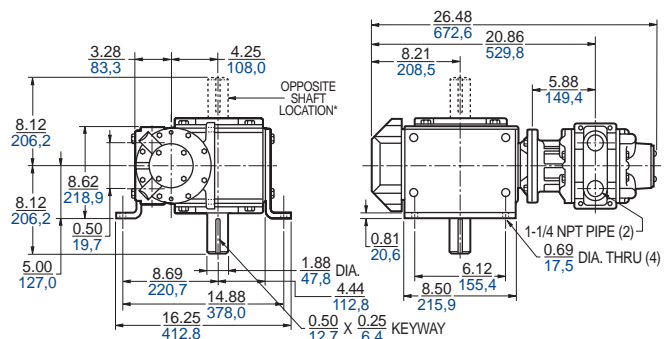

Air Consumption vs. Speed

